

- Célula de carga de tracción/compresión
- 3000 divisiones OIML R60 clase C
- Soporte elástico de acero aleado
- Protección IP 67 (EN 60529)
- Tratamiento anticorrosión de níquel duro
- Aplicaciones:
  - Tanques, Tolvas y Cintas pesadoras suspendidas de estructuras
  - Centrales de asfalto y hormigón
  - Medida de fuerza en maquinaria de ensayo
  - Pesaje aéreo

- Tension/compression load cell
- 3000 divisions OIML R60 class C
- Measuring element from Alloy Steel
- Protected IP 67 (EN 60529)
- Protected against corrosion by nickel-plated treatment
- Applications:
  - Suspended weighing in Tanks, Hoppers and Belt Conveyor Scales
  - Asphalt and Concrete Plants
  - Force measurement in Test Equipment
  - Crane scales

Modelo Model	Carga nominal Nominal capacity Ln	Clase de precisión Accuracy class n. OIML	División mínima Minimum division vmin	Carga de servicio Service load 150% Ln	Carga límite Safe load 300% Ln
630 25 kg	25 kg	3000	2.5 g	37.5 kg	75 kg
630 50 kg	50 kg	3000	5 g	75 kg	150 kg
630 100 kg	100 kg	3000	10 g	150 kg	300 kg
630 250 kg	250 kg	3000	25 g	375 kg	750 kg
630 500 kg	500 kg	3000	50 g	750 kg	1500 kg
630 1000 kg	1000 kg	3000	100 g	1500 kg	3000 kg
630 2500 kg	2500 kg	3000	250 g	3750 kg	7500 kg

**MODELO 630**

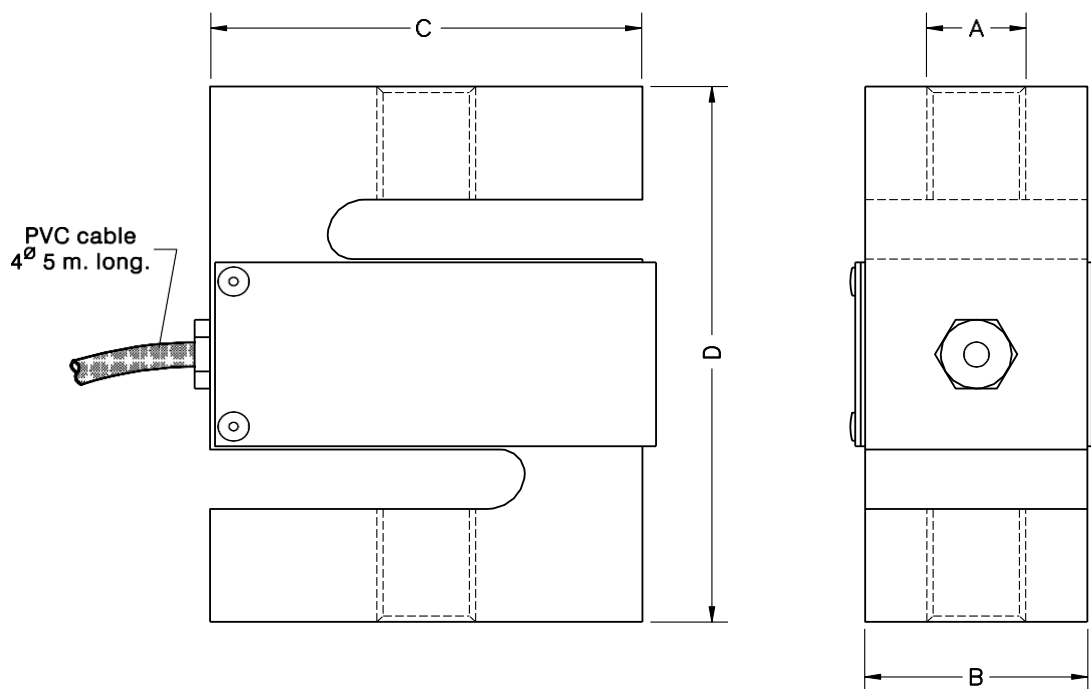

Carga nominal Nominal load	A	B	C	D	Peso transporte Transport weight
25-50-100 kg	M8x1.25	15	50.8	63.5	0.4 kg
250-500-1000 kg	M12x1.25	19	50.8	76.2	0.6 kg
2500 kg	M20x1.5	25.4	76.2	108	1.3 kg

Dimensiones en mm. *Dimensions in mm.*

ESPECIFICACIONES			SPECIFICATIONS
Cargas nominales (Ln)	25-50-100-250 500-1000-2500	kg	Nominal capacities (Ln)
Clase de precisión	3000	n. OIML	Accuracy class
Carga mínima	0	%Ln	Minimum dead load
Carga de servicio	150	%Ln	Service load
Cargas límite	300	%Ln	Safe load limit
Error combinado	< ±0.017	%Sn	Total error
Error repetibilidad	< ±0.015	%Sn	Repeatability error
Efecto de la temperatura: en el cero	< ±0.01	%Sn/5 °C	Temperature effect: on zero
en la sensibilidad	< ±0.006	%Sn/5 °C	on sensitivity
Error de fluencia (30 minutos)	< ±0.016	%Sn	Creep error (30 minutes)
Compensación de temperatura	-10...+40	°C	Temperature compensation
Límites de temperatura	-30...+70	°C	Temperature limits
Sensibilidad nominal (Sn)	2 ±0.1%	mV/V	Nominal sensitivity (Sn)
Tensión de alimentación nominal	10	V	Nominal input voltage
Tensión de alimentación máxima	15	V	Maximum input voltage
Resistencia de entrada	400 ±20	Ω	Input impedance
Resistencia de salida	350 ±3	Ω	Output impedance
Desequilibrio inicial	< ±2	%Sn	No load output
Resistencia de aislamiento	> 5000	MΩ	Insulation resistance
Deformación máxima (a Ln)	0.3-0.5	mm	Maximum deflection (at Ln)

CONEXIÓN ELÉCTRICA  
ELECTRICAL CONNECTION:

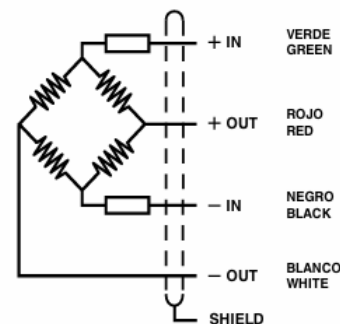

«CONVENIO SIGNOS SALIDA PARA TRACCIÓN»

«OUTPUT SIGNS FOR TENSION APPLICATION»

**ACCESORIO TRACCION PARA MOD. 630**  
**TENSION ACCESSORY FOR MODEL 630**

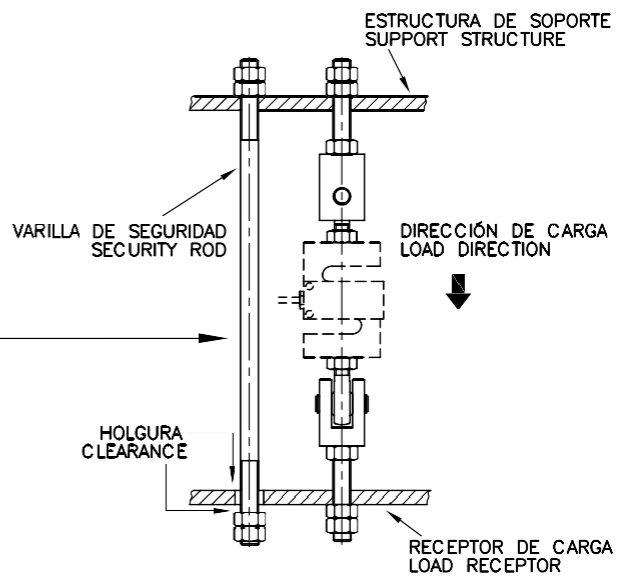
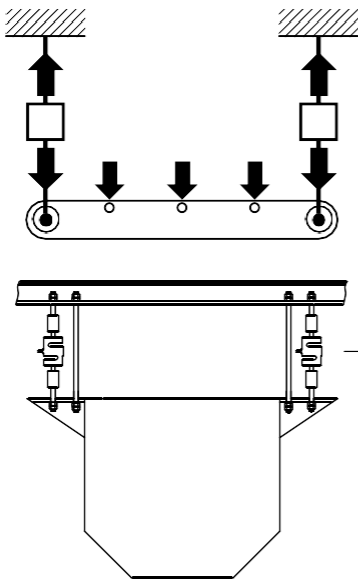
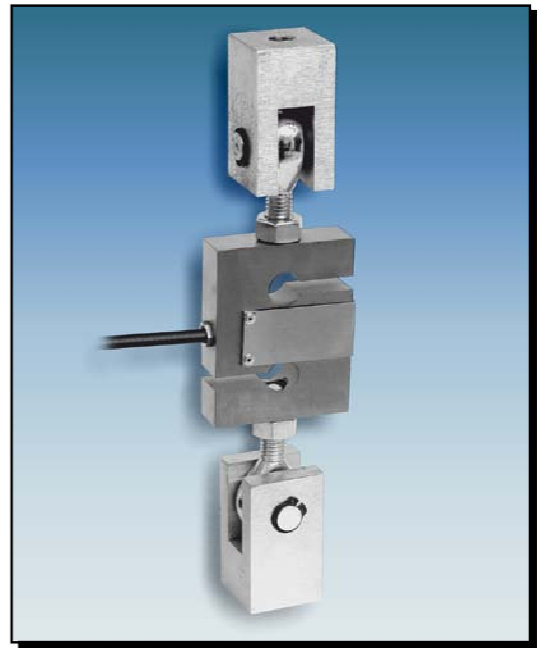
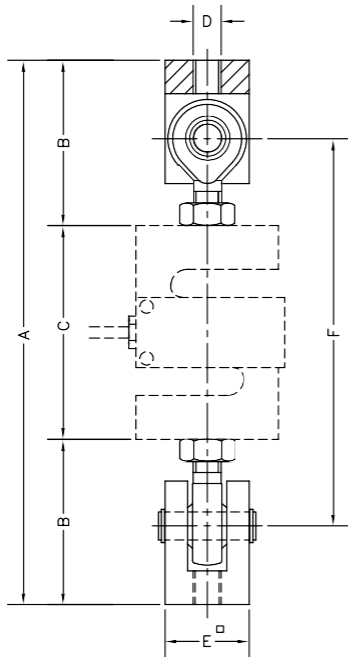

- Cada accesorio contiene un juego con la parte superior y la parte inferior.
- Each accessory contains a set of the top and bottom.

Accesorio Accessory	Carga nominal Nominal load	A	B	C	D	E <sup>□</sup>	F	Carga límite Ultimate load	Peso transporte Transport weight	Material
<b>TE8x1.25</b>	25-50-100 kg	181	58.8	63.5	M8x1.25	25	125	400 kg	0.6 kg	Acero cincado Steel zinc-plated
<b>TE12x1.25</b>	250-500-1000 kg	242.2	83	76.2	M12x1.75	35	154.2	2580 kg	1.4 kg	
<b>TE20x1.5</b>	2500 kg	340	116	108	M20x2.5	50	212	5050 kg	4.5 kg	

Dimensiones en mm. *Dimensions in mm.*

**ROTULAS PARA EL MODELO 630**  
**ROD ENDS FOR MODEL 630**

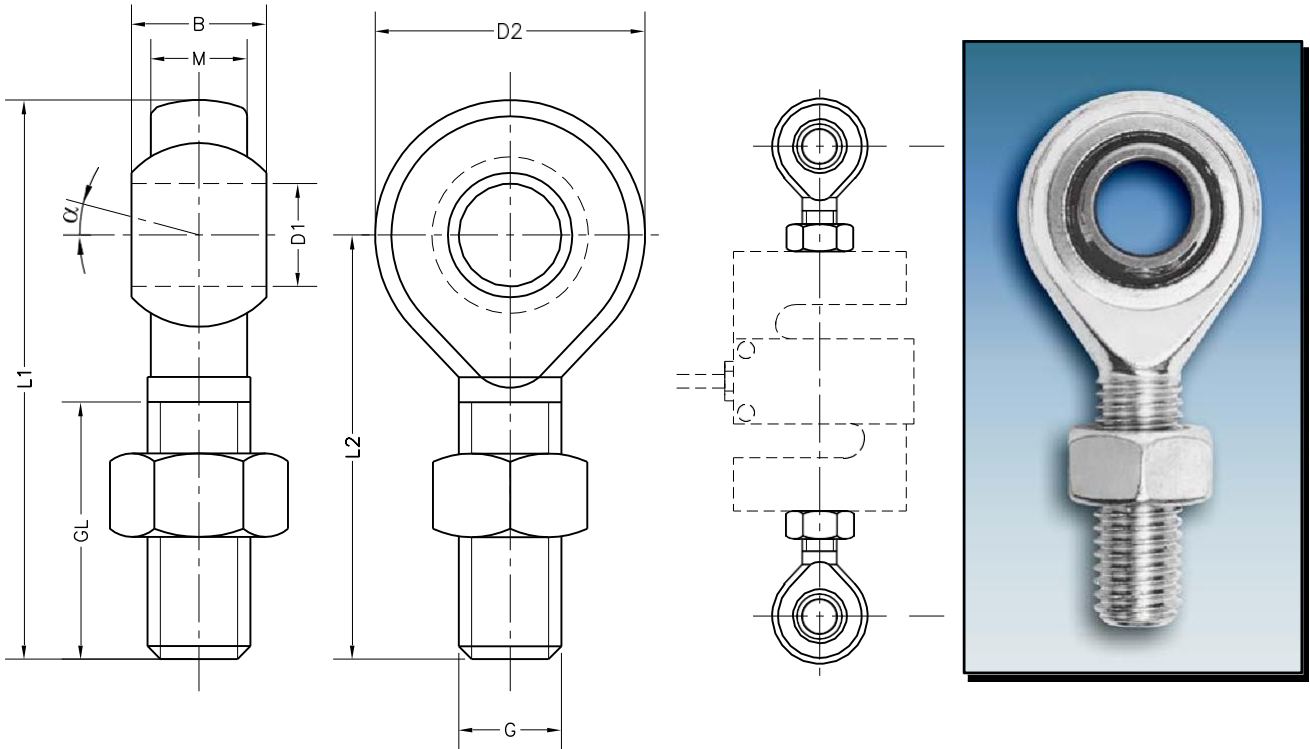

- Material: Acero cincado
- Cada accesorio RO contiene un juego de: 2 rótulas y 2 tuercas

- Material: Steel zinc-plated
- Each accessory RO includes a set of: 2 rod ends and 2 nuts

Dimensiones Accesorios RO/ RO Accessories Dimensions												
Accesorio Accessory	Capacidad/ Capacity (kg)	D2	B	M	D1	L1	L2	GL	G	$\alpha$	F	Peso transp. Trans. weight
<b>R08x1.25</b>	25-50-1000	24	12	9	Ø8	54	42	25	M8x1.25	13°	125	0.2 kg
<b>R012x1.25</b>	250-500-1000	32	16	12	Ø12	70	54	33	M12x1.25	13°	154.2	0.2 kg
<b>R020x1.5</b>	2500	50	25	18	Ø20	103	78	47	M20x1.5	15°	212	0.8 kg

Dimensiones en mm. *Dimensions in mm.*