

Stainless Steel, Multi-Column Compression Load Cell



FEATURES

- Rated capacities of 50000 to 200000 pounds, 23 to 91 metric tons
- Stainless steel, welded seal construction
- Multi-column *monolithic element* design
- 35 feet [10.7 m] standard cable length
- Three times side loading tolerance relative to similar competitive products
- Reduced eccentric loading sensitivity
- Integral conduit adaptor
- Replacement for models RTI 792 and BLH C2P1
- Trade certified for NTEP Class III: 5000d, IIIL: 10000d and OIML R-60 3000d
- Welded *Sensorgage™* sealed to IP66/67 standards
- *Cell Guard™* two year warranty

DESCRIPTION

The 65088-114 is a high capacity, stainless steel compression load cell.

The unique four column design offers excellent insensitivity to eccentric loads. This design is suitable for use in truck scales, rail scales and silo weighing applications.

This product's stainless steel construction, welded seals and IP67 rating ensure ultimate survivability under harsh conditions.

This load cell is rated intrinsically safe by the Factory Mutual System (FM); making it suitable for use in potentially explosive environments. This load cell is certified for Legal For Trade applications by both American NTEP and International OIML standards.

APPLICATIONS

- Truck scales
- Railroad track scales
- Tank, bin and weighing applications

OUTLINE DIMENSIONS in inches [mm]

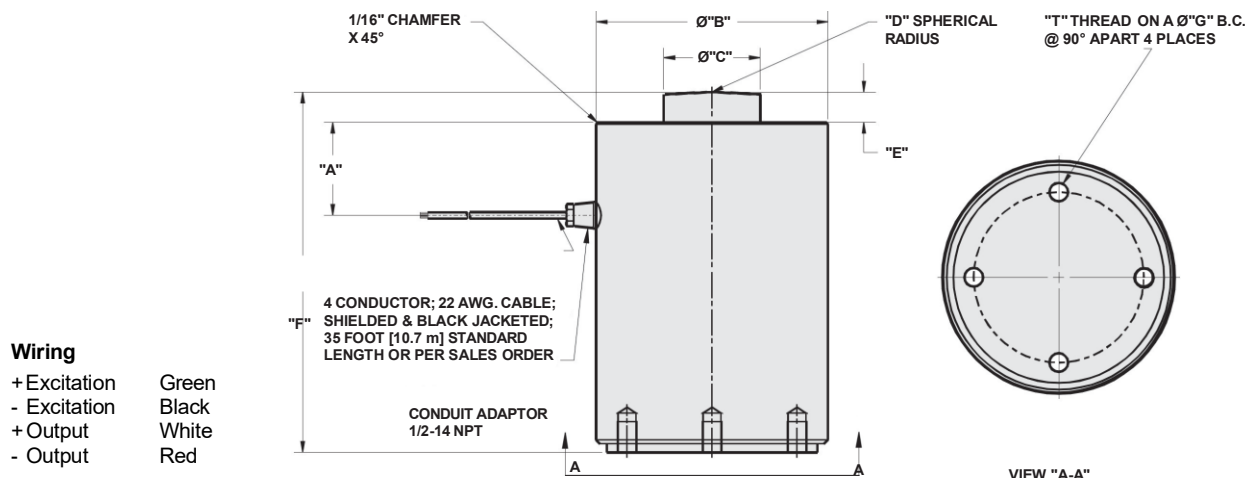

Capacities are in pounds [kg/t]. Deflection is $\pm 10\%$. Certified drawings are available.

Model 65088-0114

Sensortronics

Stainless Steel, Multi-Column Compression Load Cell



CAPACITY	A	B	C	D	E	F	G	T	DEFLECTION	WEIGHT
50K	1.17	4.50	1.25	8.00	0.75	7.50	2.38	3/8-24 UNF-2B x .63 DEEP	0.003	15.0
100K	2.00	5.75	1.75	12.00	0.87	9.13	4.00	1/2-20 UNF-2B x .75 DEEP	0.006	35.0
200K	2.93	7.50	2.50	12.00	0.97	11.63	5.50	5/8-18 UNF-2B x 1.00 DEEP	0.006	55.0
[23 t]	[29.7]	[114.3]	[31.7]	[203.2]	[19.0]	[190.5]	(60.5)	3/8-24 UNF-2B x .63 DEEP	[0.1]	[6.8]
[45 t]	[50.8]	[146.0]	[44.5]	[304.8]	[22.1]	[231.9]	[101.6]	1/2-20 UNF-2B x .75 DEEP	[0.2]	[15.9]
[91 t]	[74.4]	[190.5]	[63.5]	[304.8]	[24.6]	[295.4]	[139.7]	3/8-24 UNF-2B x .63 DEEP	[0.2]	[25.0]

SPECIFICATIONS

PARAMETER	VALUE				UNIT
Rated capacities	50K, 100K, 200K 23 t, 45 t, 91 t				lbs kgs/metric tons
Full scale output (FSO)	2.0 \pm 0.50%				mV/V
Accuracy class	NTEP III	NTEP IIII	Standard	OIML R60	
Max. no. of verification intervals	5000 multiple	10000 multiple	--	3000	
Combined error	--	--	≤ 0.03	--	% FSO
Nonlinearity	--	--	≤ 0.03	--	% FSO
Hysteresis	--	--	≤ 0.02	--	% FSO
Creep error (20 minutes)	--	--	≤ 0.03	--	% FSO
Temperature effect on zero	--	--	≤ 0.0015	--	% FSO/ $^{\circ}$ F
Temperature effect on output	--	--	≤ 0.0008	--	% of load/ $^{\circ}$ F
Non-repeatability	≤ 0.1				% FSO
Zero balance	≤ 1.0				% FSO
Insulation resistance at 50 VDC	> 1000				M Ω
Compensated temperature range	14 to 104 (-10 to 40)				$^{\circ}$ F ($^{\circ}$ C)
Operating temperature range	0 to 150 (-18 to 65)				$^{\circ}$ F ($^{\circ}$ C)
Storage temperature range	-60 to 185 (-50 to 85)				$^{\circ}$ F ($^{\circ}$ C)
Input resistance	350 \pm 3.5				Ω
Output resistance	350 \pm 3.5				Ω
Recommended excitation voltage	10				VDC
Maximum excitation voltage	25				VDC
Safe sideload	30				% of rated capacity
Safe overload	150				% of rated capacity
Ultimate overload	300				% of rated capacity
Sealing	IP66/67				
Material					
Element	15-5 PH stainless steel				
Canister	304 stainless steel				

All specifications subject to change without notice.

Disclaimer

All product specifications and data are subject to change without notice.

Vishay Precision Group, Inc., its affiliates, agents, and employees, and all persons acting on its or their behalf (collectively, "Vishay Precision Group"), disclaim any and all liability for any errors, inaccuracies or incompleteness contained herein or in any other disclosure relating to any product.

Vishay Precision Group disclaims any and all liability arising out of the use or application of any product described herein or of any information provided herein to the maximum extent permitted by law. The product specifications do not expand or otherwise modify Vishay Precision Group's terms and conditions of purchase, including but not limited to the warranty expressed therein, which apply to these products.

No license, express or implied, by estoppel or otherwise, to any intellectual property rights is granted by this document or by any conduct of Vishay Precision Group.

The products shown herein are not designed for use in medical, life-saving, or life-sustaining applications unless otherwise expressly indicated. Customers using or selling Vishay Precision Group products not expressly indicated for use in such applications do so entirely at their own risk and agree to fully indemnify Vishay Precision Group for any damages arising or resulting from such use or sale. Please contact authorized Vishay Precision Group personnel to obtain written terms and conditions regarding products designed for such applications.

Product names and markings noted herein may be trademarks of their respective owners.