

S-Type Stainless Steel Load Cell

FEATURES

- Capacity range: 500–5000 kg
- Stainless steel construction
- Sealed by welding to IP68
- S-type design for use in tension and compression
- OIML approved to 3000d (500–5000 kg)
- NTEP approved to 5000d (500–5000 kg)
- Choice of mounting threads metric or unified systems
- 6-Wire cable (sense circuit)
- **Optional**
 - Ex ia IIC T6-ATEX hazardous area approval
 - Class I, II, III Division 1 – FM hazardous area approval
 - IECEx approval available

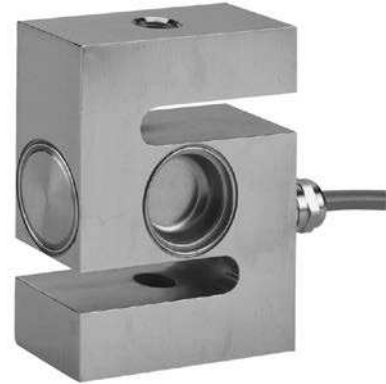

APPLICATIONS

- Hopper (tank Weighing)
- Hybrid scales
- Belt weighing
- Lever arm conversions
- Material testing machines
- Vibrations filling equipment
- Dynamometers

DESCRIPTION

The Model 620 is a stainless steel S-type load cell. Its welded sealing combined with high accuracy, make this load cell ideally suited for a wide range of applications of process weighing and force measurements.



Approvals include OIML C3 (3000d); NTEP 3000d single and NTEP 5000d multiple.

Also available are versions approved for hazardous areas—ATEX II 1 GD Ex ia T6 for Europe and FM I, II, III Division 1 for the USA.

The six-wire cable includes two sense wires that compensate for changes in lead resistance due to temperature changes and cable extension.

The Model 620 offers a choice of bolt threads in metric or unified systems; see table below.

OUTLINE DIMENSIONS in millimeters

Wiring Schematic Diagram

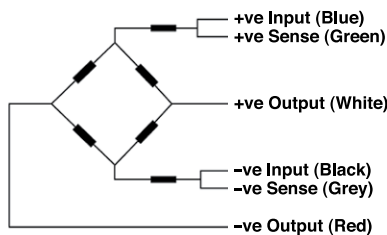

Thread Type "T" by Capacity		
Capacity	Metric	Unified
500 kg	M12 x 1.75	1/2-20 UNF
1000 kg	M16 x 2.0	1/2-20 UNF
2000 kg	M16 x 2.0	3/4-16 UNF
5000 kg	M24 x 2.0	1 - 12 UNF

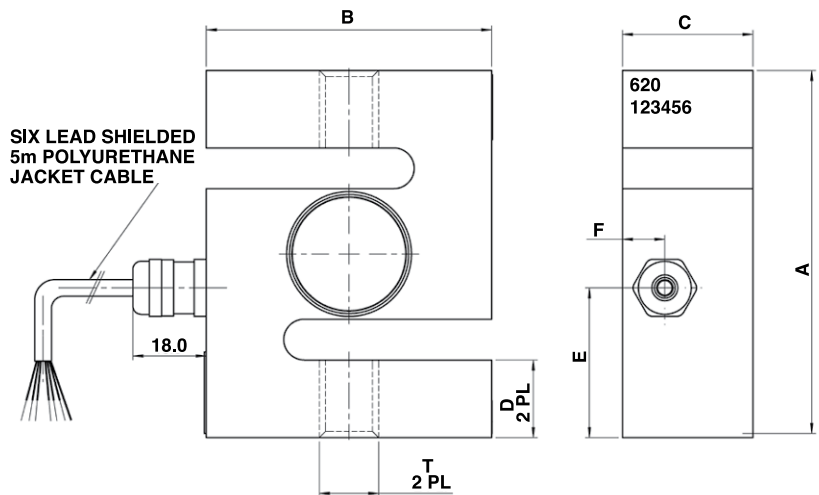

Optional rod end bearings for use with all VPG Transducers S-type load cells are available—consult the sales office.

Capacity	A	B	C	D	E	F
500, 1000, 2000 kg	90	70	32	19	36.6	10.4
5000 kg	120	100	45	26	60	13.8

S-Type Stainless Steel Load Cell

SPECIFICATIONS					
PARAMETER	VALUE				UNIT
Rated capacity – R.C. (E_{max})	500, 1000, 2000, 5000				kg
NTEP/OIML	NTEP	Non-Approved	C2/50	C3/50	
Maximum no. of intervals (n)	Class III	1000	2000*	OIML 3000	
$Y = E_{max}/V_{min}$	5000	2000	4000	6000	
Rated output – R.O.	2.0				mV/V
Rated output tolerance	0.002				±mV/V
Zero balance	0.04	0.06	0.04	0.04	±mV/V
Total error (per OIML R60)	0.0200	0.0500	0.0300	0.0200	±% of R.O.
Zero return, 30 min.	0.010	0.0500	0.0250	0.0170	±% of applied load
Temperature effect on zero	0.00112 (0.00062)	0.0070	0.0035	0.0023	±% of R.O./°C (°F)
Temperature effect on output	0.0018 (0.0010)	0.0400	0.0014	0.0012	±% of applied load/°C (°F)
Temperature range, compensated	-10 to +40				°C
Temperature range, safe	-30 to +90				°C
Maximum safe static overload	150				% of R.C.
Excitation, recommended	10				VDC or VAC RMS
Excitation, maximum	15				VDC or VAC RMS
Input impedance	400±20				Ω
Output impedance	350±3				Ω
Insulation resistance	>1000	>2000	>2000	>2000	MΩ
Construction	Stainless steel				
Environmental protection	IP68				

All specifications subject to change without notice.

Disclaimer

ALL PRODUCTS, PRODUCT SPECIFICATIONS AND DATA ARE SUBJECT TO CHANGE WITHOUT NOTICE.

Vishay Precision Group, Inc., its affiliates, agents, and employees, and all persons acting on its or their behalf (collectively, "VPG"), disclaim any and all liability for any errors, inaccuracies or incompleteness contained herein or in any other disclosure relating to any product.

The product specifications do not expand or otherwise modify VPG's terms and conditions of purchase, including but not limited to, the warranty expressed therein.

VPG makes no warranty, representation or guarantee other than as set forth in the terms and conditions of purchase. **To the maximum extent permitted by applicable law, VPG disclaims (i) any and all liability arising out of the application or use of any product, (ii) any and all liability, including without limitation special, consequential or incidental damages, and (iii) any and all implied warranties, including warranties of fitness for particular purpose, non-infringement and merchantability.**

Information provided in datasheets and/or specifications may vary from actual results in different applications and performance may vary over time. Statements regarding the suitability of products for certain types of applications are based on VPG's knowledge of typical requirements that are often placed on VPG products. It is the customer's responsibility to validate that a particular product with the properties described in the product specification is suitable for use in a particular application. You should ensure you have the current version of the relevant information by contacting VPG prior to performing installation or use of the product, such as on our website at vpgsensors.com.

No license, express, implied, or otherwise, to any intellectual property rights is granted by this document, or by any conduct of VPG.

The products shown herein are not designed for use in life-saving or life-sustaining applications unless otherwise expressly indicated. Customers using or selling VPG products not expressly indicated for use in such applications do so entirely at their own risk and agree to fully indemnify VPG for any damages arising or resulting from such use or sale. Please contact authorized VPG personnel to obtain written terms and conditions regarding products designed for such applications.

Product names and markings noted herein may be trademarks of their respective owners.

Copyright Vishay Precision Group, Inc., 2014. All rights reserved.